

**Modular Cooking Range Line
EVO900 Full Module Electric
Hob Cooking Top**

ITEM # _____

MODEL # _____

NAME # _____

SIS # _____

AIA # _____



392047 (Z9HOEH4000) Full module electric hob with mild steel top

Short Form Specification

Item No. _____

Large cooking surface with 4 independently controlled cooking zones. Large flat cooking surface made of mild steel, permits the use of a number of various sized pots and pans, all easily movable across the surface without lifting. Exterior panels in stainless steel. Worktop in 20/10, stainless steel. Right angled side edges eliminate gaps and possible dirt traps between units.

Main Features

- 4 heating zones independently controlled.
- Hob top made of mild steel, smooth and easy to clean.
- Heating via armoured elements.
- Setting different temperature zones provides a temperature gradient over the plate for different cooking needs.
- Various sizes of pans can be used at the same time due to large surface area with no intermediate sectors.
- Pans can easily be moved from one area to another without lifting.
- All major compartments located in front of unit for ease of maintenance.
- The special design of the control knob system guarantees against water infiltration.
- Suitable for countertop installation.

Construction

- Unit is 930 mm deep to give a larger working surface area.
- All exterior panels in Stainless Steel with Scotch Brite finishing.
- Model has right-angled side edges to allow flush fitting joints between units, eliminating gaps and possible dirt traps.
- Unit is 900mm deep to give a larger working surface area.
- IPX5 water resistance certification.

Optional Accessories

- Junction sealing kit PNC 206086
- Draught diverter, 150 mm diameter PNC 206132
- Matching ring for flue condenser, 150 mm diameter PNC 206133
- Side handrail for right/left hand PNC 206165
- Frontal handrail 800 mm PNC 206167
- Half module overshelf PNC 206183
- Full module overshelf PNC 206184
- Large handrail (portioning shelf) 400 mm PNC 206185
- Large handrail (portioning shelf) 800 mm PNC 206186
- Frontal handrail 1200 mm PNC 206191
- Frontal handrail 1600 mm PNC 206192
- Water column with swivel arm (water column extension not included) PNC 206289
- Water column extension PNC 206290
- 2 side covering panels, height 250 mm, depth 900 mm PNC 206321
- Base support for feet or wheels - 800mm (EVO700/900) PNC 206367

APPROVAL: _____

Front

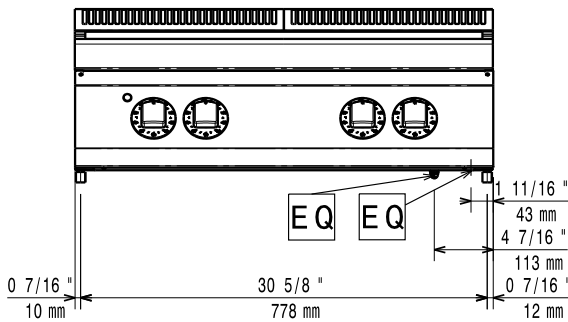

Side

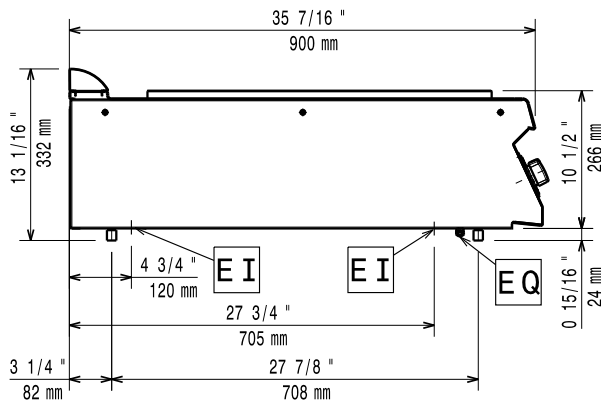

EI = Electrical inlet (power)
EQ = Equipotential screw

Top

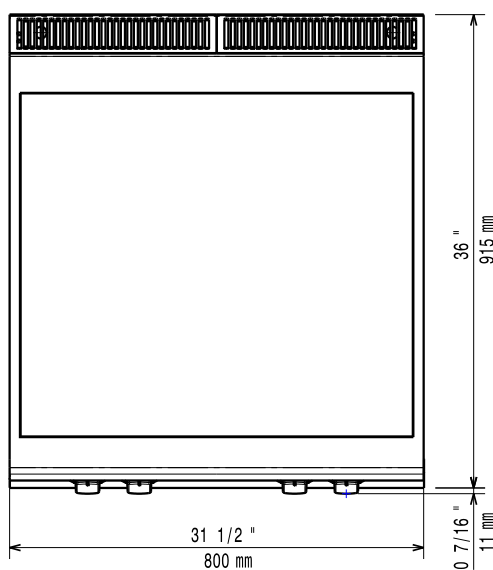

Electric

Supply voltage: 380-400 V/3N ph/50-60 Hz
Total Watts: 14 kW

Key Information:

External dimensions, Width: 800 mm
External dimensions, Depth: 900 mm
External dimensions, Height: 250 mm
Net weight: 105 kg
Shipping weight: 94 kg
Shipping height: 540 mm
Shipping width: 900 mm
Shipping depth: 1020 mm
Shipping volume: 0.5 m³

If appliance is set up or next to or against temperature sensitive furniture or similar, a safety gap of approximately 150 mm should be maintained or some form of heat insulation fitted.